

Type PKIII

Butterfly flap valve for Gaseous Media Electro-Pneumatic Operated

Edition: 07.18

Subject to change without notice

APPLICATION AREA

- > Gas firing systems on steam boilers
acc. to DIN EN12952/12953
- > Industrial thermoprocessing equipment
acc. to DIN EN 746
- > Pipe systems for gaseous fuels
for all industrial sectors

ADVANTAGE

- > Closing time < 3 seconds
- > Safety guaranteed by the proven
sealing system with soft seal
(leakage rate A in acc. with EN 12266-1)
- > Closing of the valve is dampened to reduce
pressure surges in the pipeline
- > Heavy duty design for high amount of
operating cycles
- > High performance valve design for long service
life

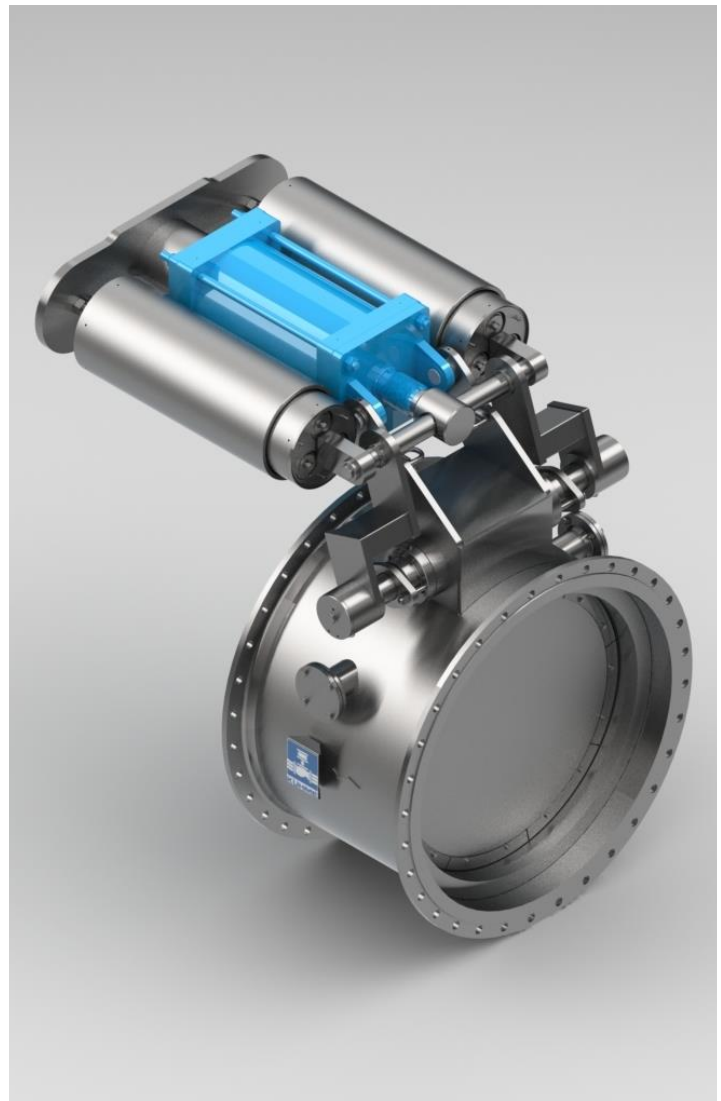

safe and reliable

Type PKIII

Butterfly flap valve for Gaseous Media Electro-Pneumatic Operated



DN 300-3000 PN 2,5-16

APPLICATION

- > Automatic operated emergency shutdown device
- > Safety device for gas burner
- > Automatic shut-off valve in piping systems

TECHNICAL DATA

- > Single-seated straight-through globe flap acc. to DIN/EN standard
- > Body and disc as welded steel construction
- > Seat ring made of stainless steel
- > Double shaft sealing with O-ring and connection for tightness test
- > Additional sealing force generated through primary pressure loaded onto the flap disc
- > On top piston actuator with closing spring set
- > Maintenance-free plain bearing teflon-based
- > Flap disc with safety metallic overload protection
- > Flap disc closing function operated parallel on flap disc sealing
- > Flap disc function generated by special double deflexion lever
- > Hydraulic closing delay

CERTIFICATES

EC-Type examination (Modul B)
acc. to directive 2014/68/EU
EC- Type examination certificate
with product-identnumber
acc. to gas appliance directive 2009/142/EC (till DN 1600)
based on:

DIN EN 13611 / DIN EN 161

- Certificate:
- > TA-Luft
DIN EN ISO 15848-1
VDI 2440
 - > SIL2 / EN 61508

OPERATING DATA

- Media:
- > Gaseous fuels acc. to PED 2014/68/EU
 - > Fuels acc. to G260; gas group 1., 2. and 3
 - > Other gaseous media
- Operating pressure:
- Max. 2,5 bar g < DN 700 (static)
 - Max. 1,0 bar g > DN 800 (static)
- Operating temperature: -25 to +300 °C
- Ambient temperature: -25 to +80 °C
- Control medium: Compressed air at 4-8 bar g
- Air quality: acc. to DIN ISO 8573-1
- Control voltage: 230 V, 50 Hz, 24 V DC
- Power: 10.6 VA / 6.8 W
- IP Protection Class: IP 65
- Mounting position: no restriction
- Mounting location: Indoor/Outdoor

CLOSING TIME

Closing time			
DN	250-500	600-1300	> 1300
90%	< 1 s	< 1 s	< 4 s
100%	< 2 s	< 3 s	< 6 s

OPTION

- > Closing by weight
- > Actuator arranged laterally
- > Dust bin

safe and reliable

Type PKIII

Butterfly flap valve for Gaseous Media Electro-Pneumatic Operated



DN 300-3000 PN 2,5-16

FUNCTION

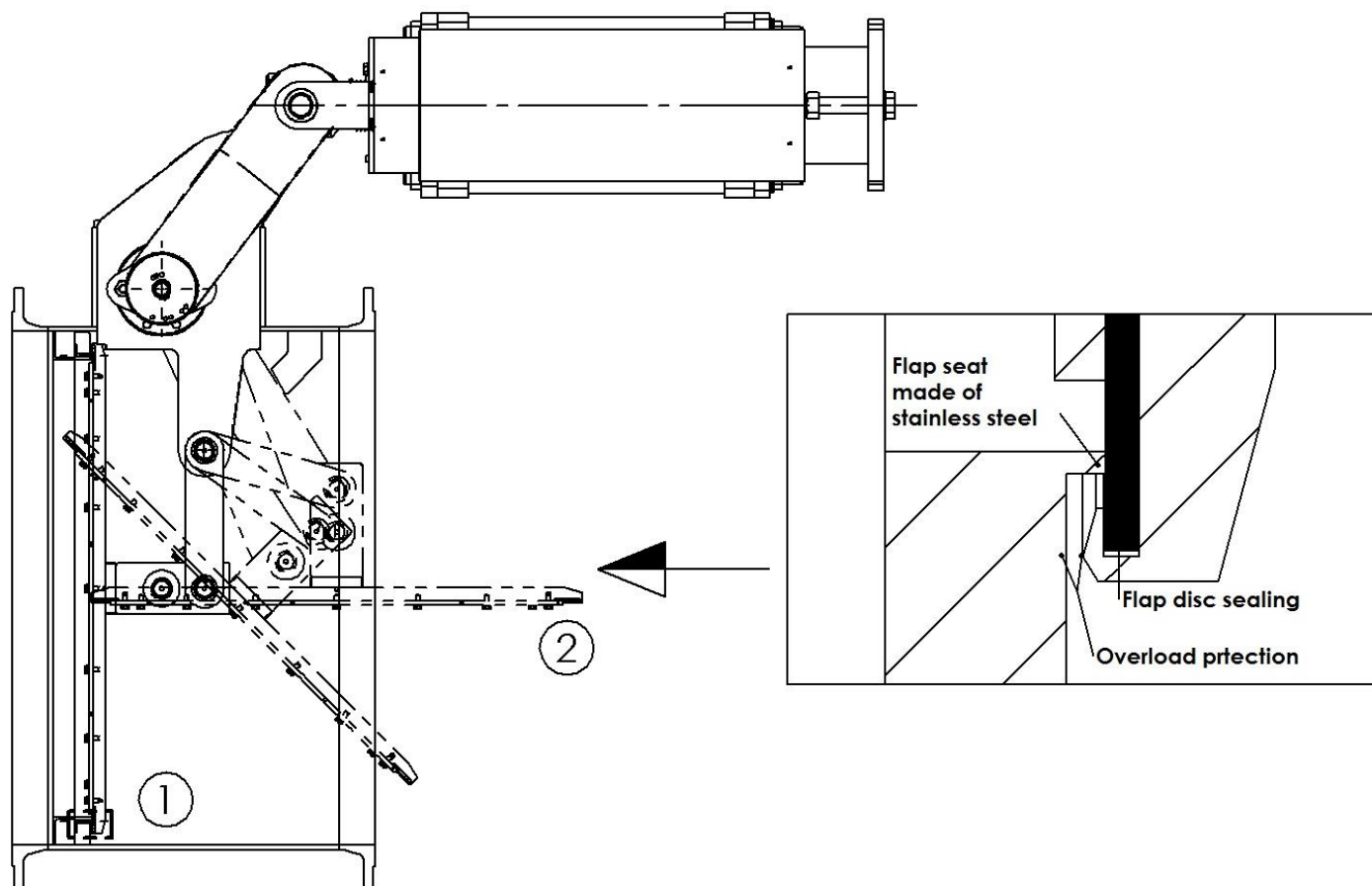

OPENING

In position [1] the flap is closed by spring force. By activating the 3/2-way solenoid valve, compressed air is admitted to the pneumatic actuator. The flap is opened against the closing springs respectively and the pressure load of the operating medium, releasing the passage. During the opening procedure, the rotary movement of the drive shaft will lift the flap disc via the driving lever from the seat, at first in parallel direction. In opened position [2], the flap disc is arranged in parallel with the axis of the casing.

CLOSING

In the case of control energy failure or fault cuts-off, the pressure volume in the pneumatic drive will be expanded via an attached quick-venting valve. The flap will be closed by the accumulated energy of the closing springs or by the closing weight respectively. The flap disc moved parallel to the flap seat. This achieves the optimum and lasting tightness.

safe and reliable

Type PKIII

Butterfly flap valve for Gaseous Media Electro-Pneumatic Operated



DN 300-3000 PN 2,5-16

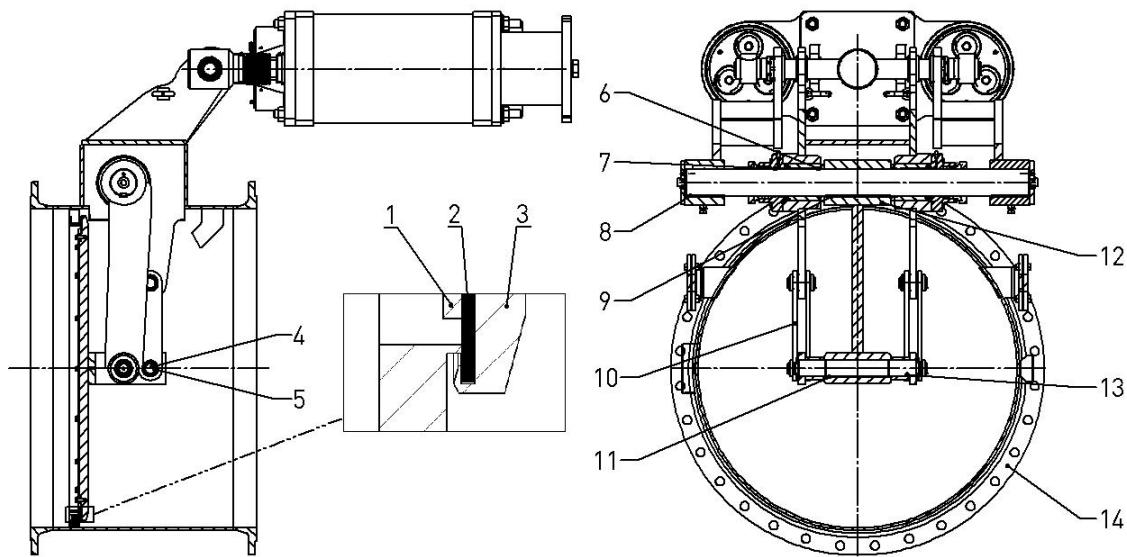

- | | | | | | | | |
|---------------|-------------------|-----|---------------|------|--------------|----|-------------|
| 1 | Clamp ring | * 5 | Plain bearing | 9 | Feather key | 13 | Feather key |
| * 2 | Flap disc sealing | * 6 | O-Ring | 10 | Steering arm | 14 | Casing |
| 3 | Flap disc | * 7 | O-Ring | * 11 | O-Ring | | |
| 4 | Actuating bolt | * 8 | Plain bearing | 12 | Center lever | | |
| * Spare parts | | | | | | | |

safe and reliable

Type PKIII

Butterfly flap valve for Gaseous Media Electro-Pneumatic Operated



DN 300-3000 PN 2,5-16

AIR CONTROL SCHEME

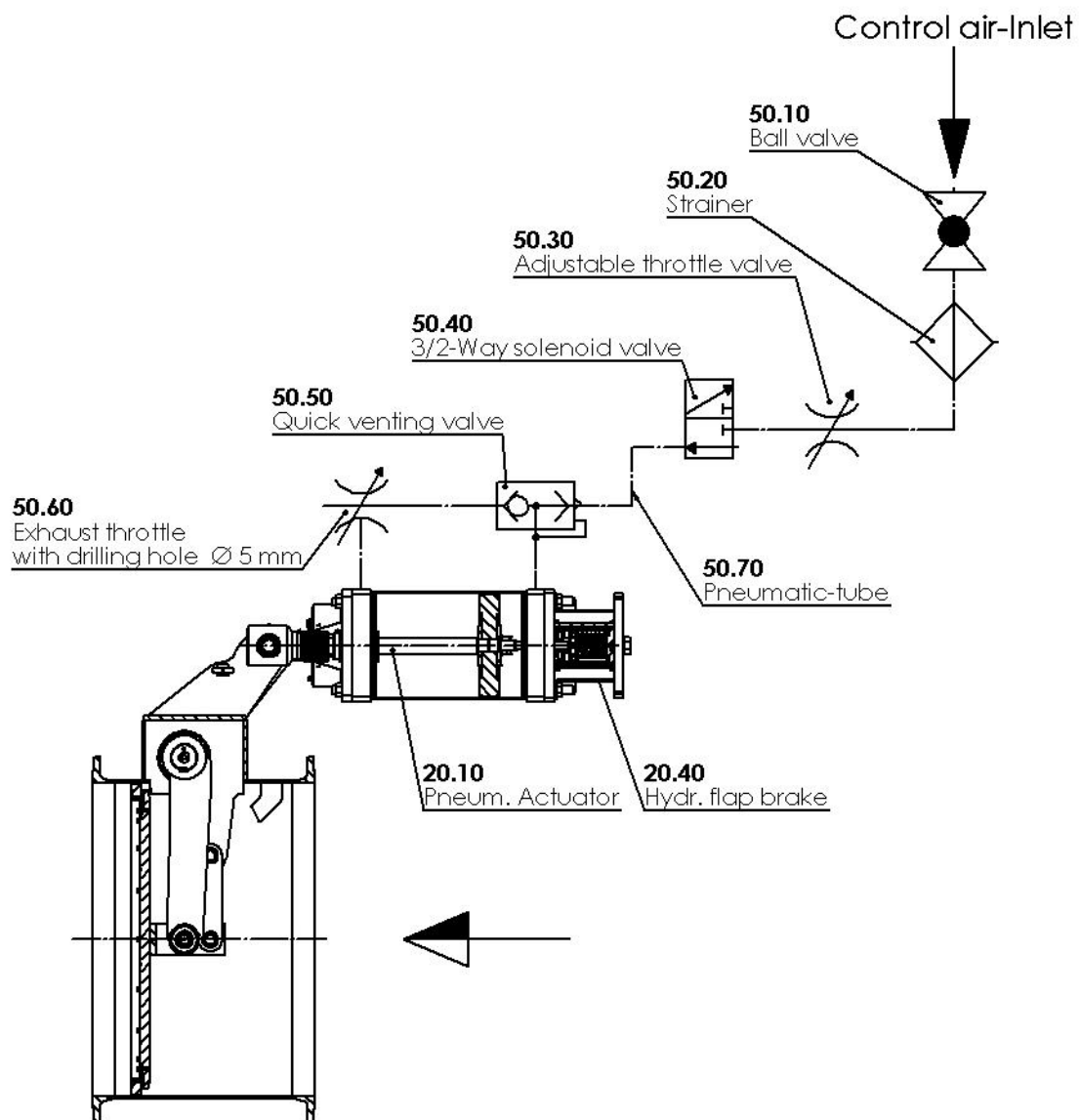

safe and reliable

Type PKIII

Butterfly flap valve for Gaseous Media Electro-Pneumatic Operated



DN 300-3000 PN 2,5-16

DIMENSIONS

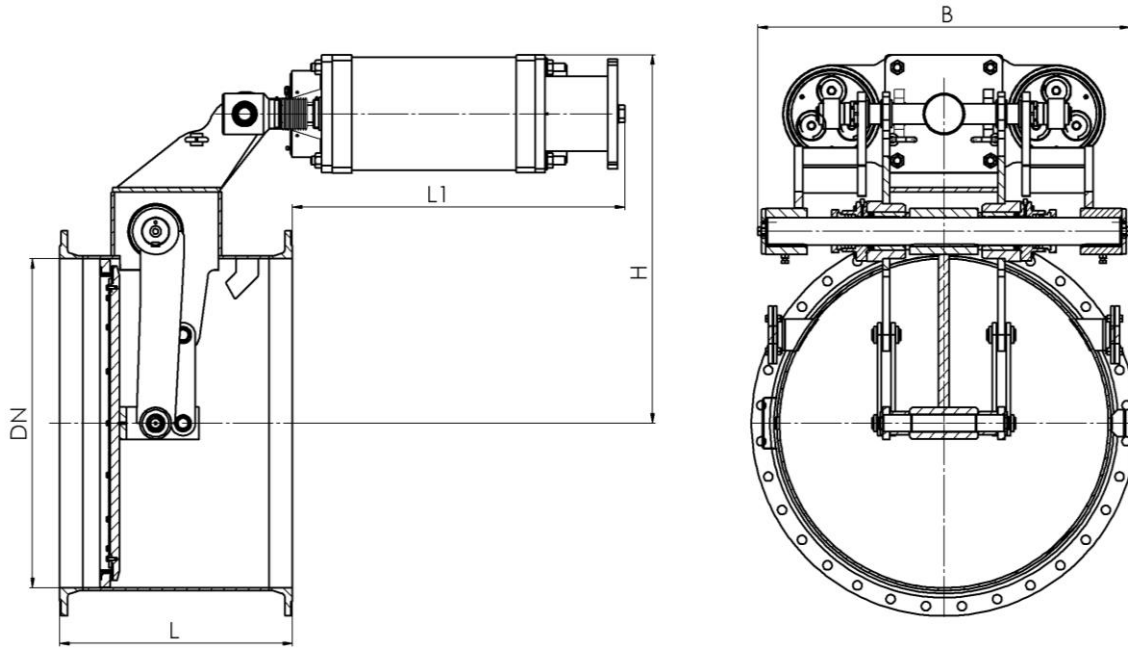

DN	mm				kg
	B	L	L1	H	Weight
300	570	400	541	497	270
350	570	400	629	521	300
400	570	400	629	540	305
450	596	450	629	570	305
500	596	500	456	672	365
600	800	600	750	800	800
700	800	700	686	893	1000
800	1105	700	725	1007	1030
900	1245	750	906	1100	1545
1000	1363	850	950	1243	2135
1100	1358	850	1058	1345	2600
1200	1358	850	1043	1345	2760
1300	1370	855	1049	1470	2700
1400	1561	950	943	1540	2800
1500	1561	1000	943	1651	3100
1600	1561	1000	803	1651	3250

> DN 1600 on request; Flange dimensions acc. to DIN